

25,000 Litre Duracrete Standard Water Tank

Standard 25,000L Above Ground



Standard 25,000L Unequally Buried

No Roof Loading Permitted

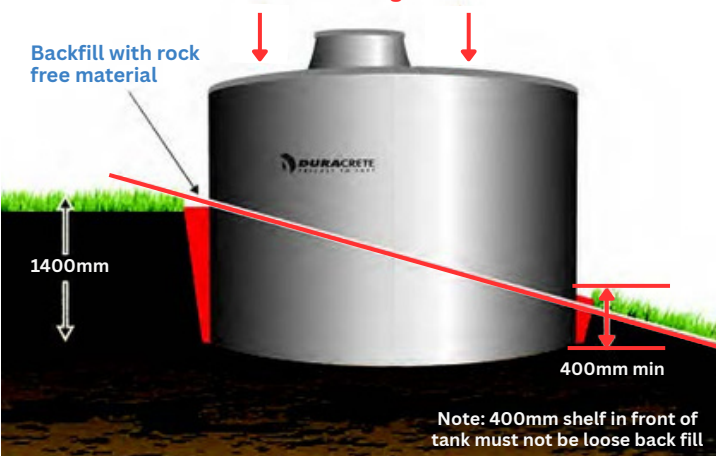

Please note tank is not designed to be used as retaining
eg. Lower side = 400mm (minimum)
Higher side = 1.400m
(1m maximum height difference)
Please refer to PS1

Standard 25,000L Tank Buried to 2.1m Max Height

No Roof Loading Permitted



Suitable for above ground installations or buried applications to maximum height of 2.1m

- All measurements +/- 10mm
- 8.25 Tonne Weight
- 65mm Average Wall Thickness
- 90mm Floor Thickness
- 70 MPA Concrete Strength

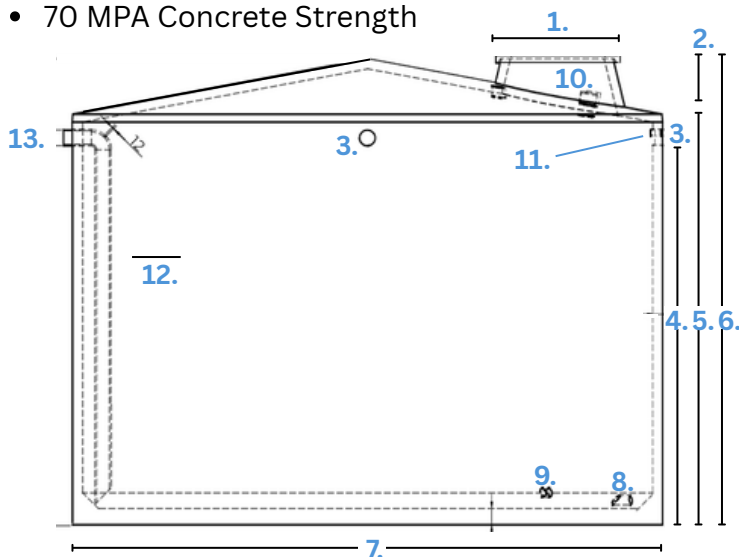

25,000L TANK DIMENSIONS

1. Hatch Opening	600mm
2. Height of Apex	350mm
3. Inlet / Outlet Knock Outs	100mm x 4
4. Water Level Height	2.40m
5. Total Wall Height (incl. roof)	2.55m OA
6. Overall Height (incl. manhole & lid)	2.90m OA
7. Outside Diameter	3.74m
8. Drain BSP	50mm x1
9. Balance BSP	50mm x2
10. SS Air Vent	100mm x1
11. Pump/Electrical Outlets	40mm x 2
12. Maximum Ground Level	2.1m
13. Overflow Siphon	Installed in knock-out as shown



Bowers & Son Ltd

Concrete Manufacturers

1852 Alexandra Street, Te Awamutu 3800 - PHONE: 07 871 5209

64 Otewa Road, Otorohanga 3900 - PHONE: 07 873 8510

EMAIL: admin@bowersconcrete.co.nz

All dimensions are nominal & subject to manufacturing tolerances.



www.bowersconcrete.co.nz

IMPORTANT NOTES OF CORRECT SITE PREPARATION

The site loading of a full 25,000 litre water tank is in excess of 33 tonnes across 3.7m diameter.

The excavated site must be free of all solid objects (rocks, tree stumps, roots, etc) and be flat, level and consistent across the tank base to allow the tank to sit evenly. A tolerance of 15mm is permitted over the entire site. This can be achieved by using a level and straight edge, laser level or similar method. An uneven foundation base will result in the tank being 'Off Plumb'. Do not reintroduce the excavated material to create a level platform.

Correct site preparation is critical in order to transfer the total combined weight of the tank and water of approx. 33 tonne to the prepared foundation. Uneven weight transfer will result in failure of the tank base and therefore will not be covered by warranty.

Tanks should be backfilled as soon as possible to seal in to the ground. The backfill material should be clean, rock free soil or similar, suitable to avoid water flow entering around tank eg. no drainage metal, rubbish etc.



Example of correct truck positioning for partial buried tank.

Note: Truck is required to be within 1.5m (from the centre of the crane to the corner of the hole) of excavation where each tank is going with truck being aligned on the diagonal of the hole.



Example of the correct truck position for unloading onto the prepared site.

Note: The trucks must be able to back up to the immediate corner where each tank is being placed). This may mean a progressive excavation / installation will be required for partial or fully buried tanks. Truck has minimal reach & will need to reposition if there is more than one tank.



Example of the correct truck position for unloading onto the prepared site.

Note: The truck must reverse to tank site and must be able to unload from the rear of the truck. Hydraulic stabilisation legs require a minimum span of 7.5m during the unloading process.



Bowers & Son Ltd
Concrete Manufacturers

1852 Alexandra Street, Te Awamutu 3800 - PHONE: 07 871 5209
64 Otewa Road, Otorohanga 3900 - PHONE: 07 873 8510
EMAIL: admin@bowersconcrete.co.nz

PROUD LICENSEE OF
DURACRETE
PRECAST TO LAST

www.bowersconcrete.co.nz

SITE PREPERATION STEPS

ALL STEPS MUST BE FOLLOWED



Excavate and level the ground which will form the base for the tank. Ground shall be “good ground” in accordance with NZBC Clause B1. Do not reintroduce excavated material to achieve a level platform. The excavated hole should be square. The final hole size should be 4.2m x 4.2m per tank and to the required depth (**maximum buried depth is 2.1m for the cone top standard tanks**, and 300mm of soil cover/2.5 tonne of light vehicle loading for underground flat roof tanks).



Add hard fill and **compact** to a depth of 100mm to a tolerance of 15mm across the site.



Add 7mm GAP granular fines as the bedding material to allow the tank to evenly settle into the site. This course should be 75mm thick and remain **uncompacted**. Evenly screed to a tolerance of 5mm over the entire site.



Bowers & Son Ltd
Concrete Manufacturers

1852 Alexandra Street, Te Awamutu 3800 - PHONE: 07 871 5209
64 Otewa Road, Otorohanga 3900 - PHONE: 07 873 8510
EMAIL: admin@bowersconcrete.co.nz

PROUD LICENSEE OF
DURACRETE
PRECAST TO LAST

www.bowersconcrete.co.nz



IMPORTANT NOTES & PURCHASER RESPONSIBILITIES

- It is the purchaser's responsibility to ensure access is clear, site preparations are complete and to the required standard when the tanks arrive. This will avoid any delays and extra time on site and potential cost overruns. Bowers & Son takes no responsibility for the site readiness or unforeseen delays on site.
- Site suitable access is the responsibility of the purchaser. Check that there are no overhead power lines, tree branches, buildings, gate posts or other obstacles blocking access to the loaded delivery truck.
- It is the purchaser's responsibility to ensure that the path required from the road to the tank site does not have drains, septic tanks, bridges or irrigation lines that the truck could either fall into or damage.
- To access site, loaded truck requires clearance of 4.25m (height) x 4m (width) and is 10.5m in length. Hiab crane requires a minimum height clearance of 8.5m during the unloading process, subject to the site conditions.
- Bowers & Son are not responsible or liable for the site preparation standards.
- On the day of installation, it is essential to install and pipe the overflow away from the tank base to prevent undermining the site.
- On the day of the installation of fully or partially buried tanks (up to 2.1m), it is critical that the tank is filled completely with water and does not exceed the overflow point.
- To prevent floatation (hydraulic uplift) issues, the tanks should remain full until connected to the water catchment.
- If installing more than two tanks in a single excavation please consult regarding lift planning. N.B. No side lifts and we cannot lift a tank over another tank.
- When purchasing multiple tanks, it is recommended that there is an accessible isolation valve between the tanks to be able to isolate one tank from the other for future maintenance purposes.
- For buried applications, tanks buried more than 300mm into the ground may require a specific design. Please refer to an engineer to decide if your site requires this.
- Buried tanks with less than 300mm of topsoil cover may require an anti-floatation sill to avoid hydraulic uplift occurring. Please refer to an engineer to determine if your site requires this.
- For partial buried tank application, anti-floatation sill may still be required if the maximum ground water table (indicated in the relevant tank model data sheet) is exceeded. Please refer to an engineer if your site requires this.
- Determining the location of tanks on your site may require an engineer's assessment and specific foundation design.
- It is the purchasers responsibility to ensure their site access and tank sites are ready to take delivery on the agreed date with our dispatch team. If there is delay, you may move to the back of the queue depending on product availability. Product may then need to be allocated to the next customer who is ready to take delivery as we cannot store tanks due to storage space limitations.
- **It is the purchaser's responsibility to pass this document on to any contractors or end users.**



Bowers & Son Ltd
Concrete Manufacturers

1852 Alexandra Street, Te Awamutu 3800 - PHONE: 07 871 5209
64 Otewa Road, Otorohanga 3900 - PHONE: 07 873 8510
EMAIL: admin@bowersconcrete.co.nz

PROUD LICENSEE OF
DURACRETE
PRECAST TO LAST

www.bowersconcrete.co.nz

WARRANTY TERMS AND CONDITIONS

All Bowers & Son Ltd products are warranted to be free from manufacturing defects and non-compliance with applicable industry standards for a period of ten (10) years from the date of purchase. This warranty is offered only to the original purchaser.

Conditions of Warranty:

Bowers & Son Ltd accept no liability for damage caused due to improper site preparation and incorrect site situations that are outside our requirements and recommendations. Refer to site preparation steps 1-3 on page 3.

Liability of Bowers & Son Ltd is limited to the repair, or if necessary, replacement of the concrete tank concerned. The decision to repair or replace the tank lies exclusively with Bowers & Son Ltd.

Preparation of the tank site is the responsibility of the purchaser or their agent.

This warranty does not cover:

- Damage caused after delivery resulting from poor, incorrect or inadequate site preparations.
- Tanks that are not placed directly on a prepared tank site at the time of delivery
- Filling of the tank with water past the overflow point before the overflow pipe is fitted.
- Blocked or incorrectly installed overflow pipe. This includes backlog of groundwater from full soakage pits and the overflow pipe not being installed to drain away from the tank base.
- Installation of partially buried tanks exceeding maximum ground levels as per the specifications.
- Tanks that are unequally buried that have greater differential of more than 1m from highest to lowest point.
- Moving the tank from its original location.
- Undermining of the ground supporting the tank in any way.
- Tanks that are painted a dark colour which attracts heat, causing the temperature differential between the inside and outside of the tank to increase. -LRV = 45% or greater. LRV (light reflectance value) please refer to paint manufacturers guides.
- Failure of plumbing or drainage connections installed by others after delivery
- Quality of water entering the tank from roof catchment and the effect this water has on the concrete inside the tank.
- Normal aging, wear and tear.
- Negligent and accidental damage that occurs after delivery and/or during installation.
- Failure resulting from natural causes (earthquakes, flooding etc.) See PS1 available on request.
- Repairs carried out by unauthorised persons.
- Use of a tank for purposes other than for which it was originally intended.
- Exceeding of the load capacity on concrete manhole lid.
- Hydraulic Uplift (Floatation).
- Flood wash tanks

If you have any further queries regarding your site, delivery of your tank, or require further information on concrete water storage tanks, please feel free to contact us.



Bowers & Son Ltd
Concrete Manufacturers

1852 Alexandra Street, Te Awamutu 3800 - PHONE: 07 871 5209
64 Otewa Road, Otorohanga 3900 - PHONE: 07 873 8510
EMAIL: admin@bowersconcrete.co.nz

PROUD LICENSEE OF
DURACRETE
PRECAST TO LAST

www.bowersconcrete.co.nz